

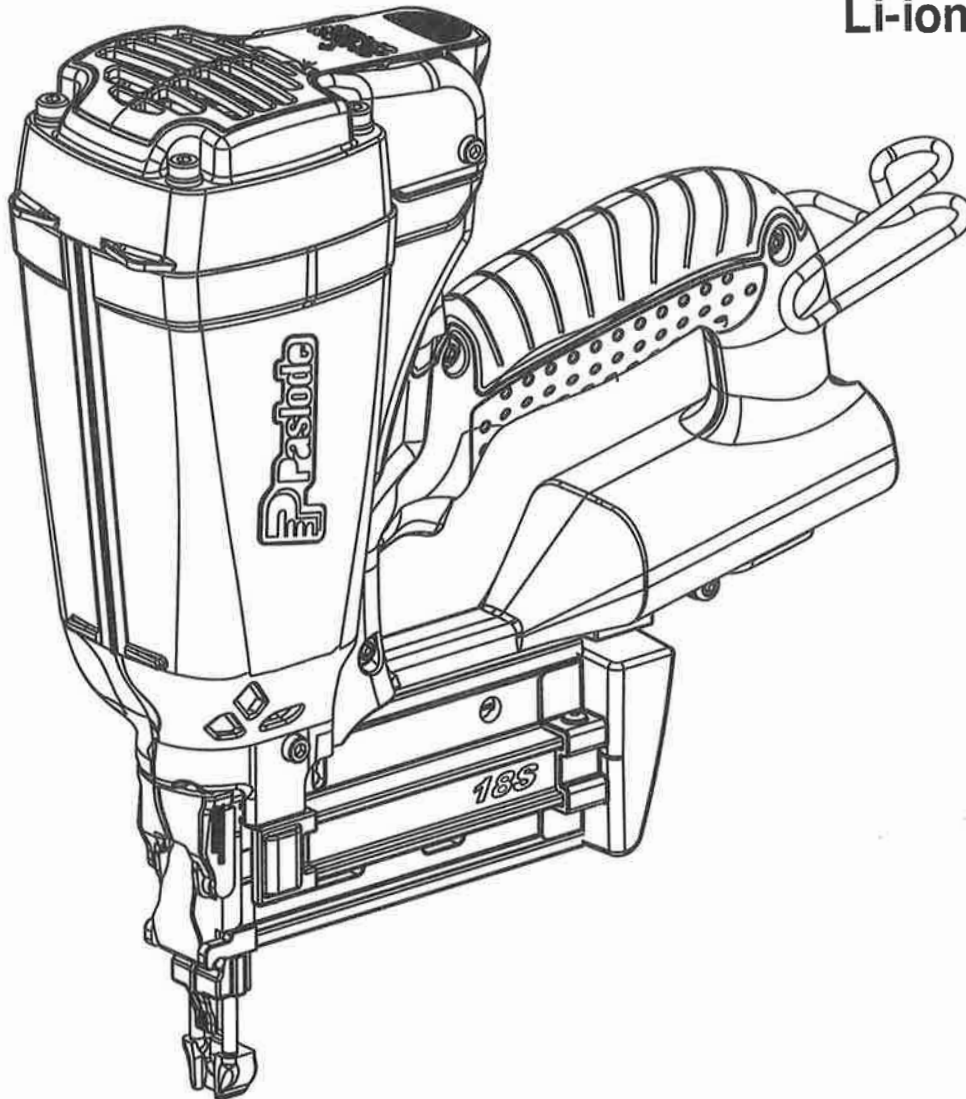

Part No. 918100

**Model IM200Li.2
18 Gauge Cordless
Li-ion Brad Nailer**



**IMPORTANT!
DO NOT DESTROY**

Always refer to operators manual for detailed information on this tool. It is the customers responsibility to have all operators and service personnel read and understand the information.

TOOL SCHEMATIC AND PARTS

PARTS LEGEND

IM200Li 18 Ga. Cordless Brad Nailer 918100

1	901064	4	S.H.C.S. 8-32 x 1-3/8"	46	901009	1	Latch Cover
2	904601	1	Grille, Black	47	901150	1	Latch Spring Clip Assembly
* 3	900648	1	Filter	48	901002	1	Front Plate
4	904557	2	Cap Screw	* 49	901048	1	Rubber Probe Tip
5	902446	1	Cap	50	903704	1	Probe
6	900785	1	Spark Plug, Insulator Sleeve	51	918922	1	Left Handle
* 7	900714	1	Spark Plug Assembly	52	901097	2	Shoulder Screw 8-32 SHCS P30
8	900596	1	Screw, Sem 8-32 x 7/16"	53	918919	2	Paslode Logo
9	900739	1	Cylinder Head Circuit Board	54	901066	4	Plastite Screw
10	901119	1	Retaining Ring, Motor	* 55	918903	2	Foam Pad, Battery
11	901382	1	Motor Assembly	** 56	918921	1	Warning Label
* 12	401356	1	Motor Sleeve	57	918928	1	Wear Strip
* 13	904546	1	Fuel Tube	58	918907	1	Magazine Base
14	902406	1	Fuel Block	59	900660	2	Screw, Rail 10-32 x 3/8 Hex Flt Hd
15	904521	1	Pivot Arm	60	901015	1	Follower
* 16	904517	1	Fuel Barb	61	901018	2	Pin, Magazine
17	901059	1	Front Channel Extrusion	* 62	901016	1	Constant Force Spring Assembly
* 18	901078	1	Piston Assembly	63	901052	1	Spring Cover
* 19	901040	1	Piston Ring	64	918905	1	Magazine Cover
20	901021	1	Bumper	* 65	901055	2	O-Ring, Retaining Ring
21	904504	1	Cylinder Head	66	901062	1	Screw, 6-32 x 1/8 BH
22	900709	1	Fan Assembly	67	901061	2	Screw, 6-32 x 3/16 BH
* 23	900612	4	Seal Ring	68	918924	1	Magazine End Cap
24	900700	1	Air Dam	69	900001	1	Magazine Latch Spring
25	900729	1	Combustion Chamber Assy.	70	918926	1	Latch Paddle
26	901036	1	Retaining Ring, Sleeve	71	901095	1	Switch Slide Assembly
27	901082	1	Trigger Assembly	72	918923	1	Right Handle
28	901038	1	Yoke Spring	73	900662	1	MSU Wire Assembly
29	900746	2	Screw,#8-32 x 7/16	74	918938	1	Molded Circuit
30	901037	1	Yoke	75	404702	1	Screw,Molded Circuit
* 31	901039	1	Yoke Bumper	76	900629	1	High Tention Clip
32	900734	1	Roll Pin	77	902440	1	Spark Unit
33	903710	1	Depth of Drive Assembly	78	904567	1	Spark Plug Wire Assembly
■ 34	405140	4	Screw 8-32 x 7/16"	79	904562	1	Fan Wire Assembly
35	900668	1	Muffler Cover	80	901044	1	Soft Grip
36	900609	1	Muffler	81	904544	1	Dosing Lever
37	900664	1	Reed Valve	82	902235	1	Retaining Ring
38	900665	1	Reed Plate	83	904550	1	Fuel Door
39	901089	1	Prefilter Disk	84	902230	1	Fuel Door Pin
* 40	900616	1	Exhaust O-Ring	85	918909	1	Utility Hook Cap Nut
■* 41	901026	2	Screw	86	918110	1	Utility Hook Button
42	901004	1	Front Plate Support	87	918911	1	Utility Hook Block
43	901025	1	Support Pin	88	918913	1	Spring, Utility Hook
* 44	901003	1	Back Plate	89	918906	1	Utility Hook, Wire Form
45	900685	1	Latch Cover Pin				

- * Denotes Normal Wear Items
- Apply Loctite RC-620 (Green)
- ** Make sure Warning Label (918921) is properly affixed replace if necessary.
- Denotes Change

SAFETY INSTRUCTIONS

WEAR EYE AND HEARING PROTECTION



Always wear hearing protection and eye protection devices, including side shields when operating or working in the vicinity of a tool.

901081 Sleeve Assembly

IM200Li
Single strip
Brad Nailer
918100

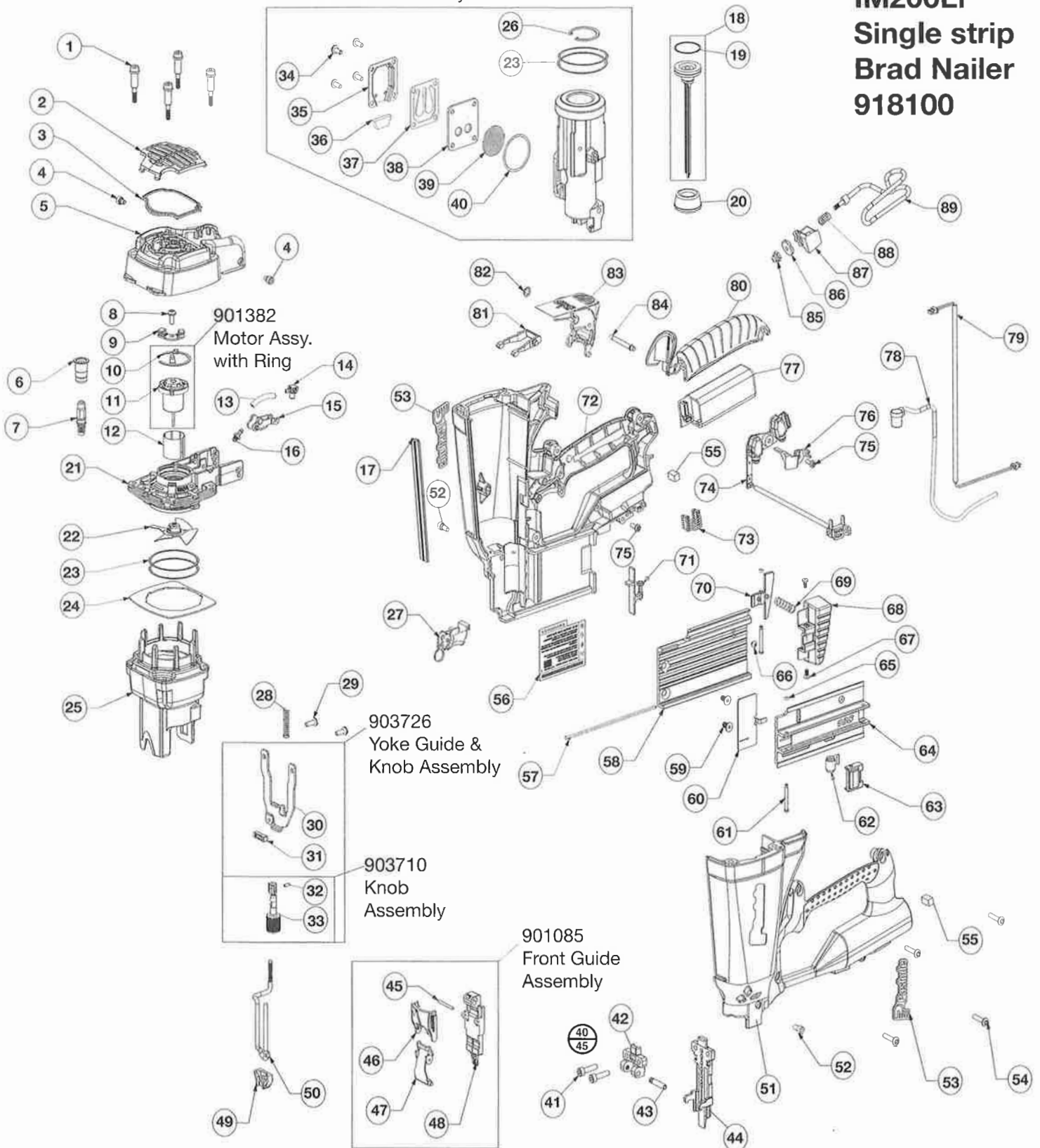

TORQUE VALUES

MIN	IN/LBS
MAX	

WARNING

All parts must be periodically inspected and replaced if worn or broken. Failure to do this can present a safety hazard.

ACCESSORIES

Carrying Case



Part No. 902445

Battery



Part No. 902654

Paslode Cordless Lubricating Oil



Part No. 401482

Torx Key - T7

For tightening fan blade to motor

Part No. 900183

Battery Charger

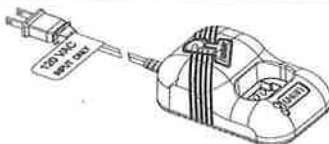

Part No. 902667

Clear Safety Glasses



Part No. 401382

Tool Cleaner

Ideal cleaner for all Paslode tools



Part No. 219348

No- Mar Tip - Hard Tip

Part No. 901048

No- Mar Tip - Soft Tip

Part No. 901067



An Illinois Tool Works Co.
155 Harlem Avenue
Glenview, IL 60025
www.paslode.com