

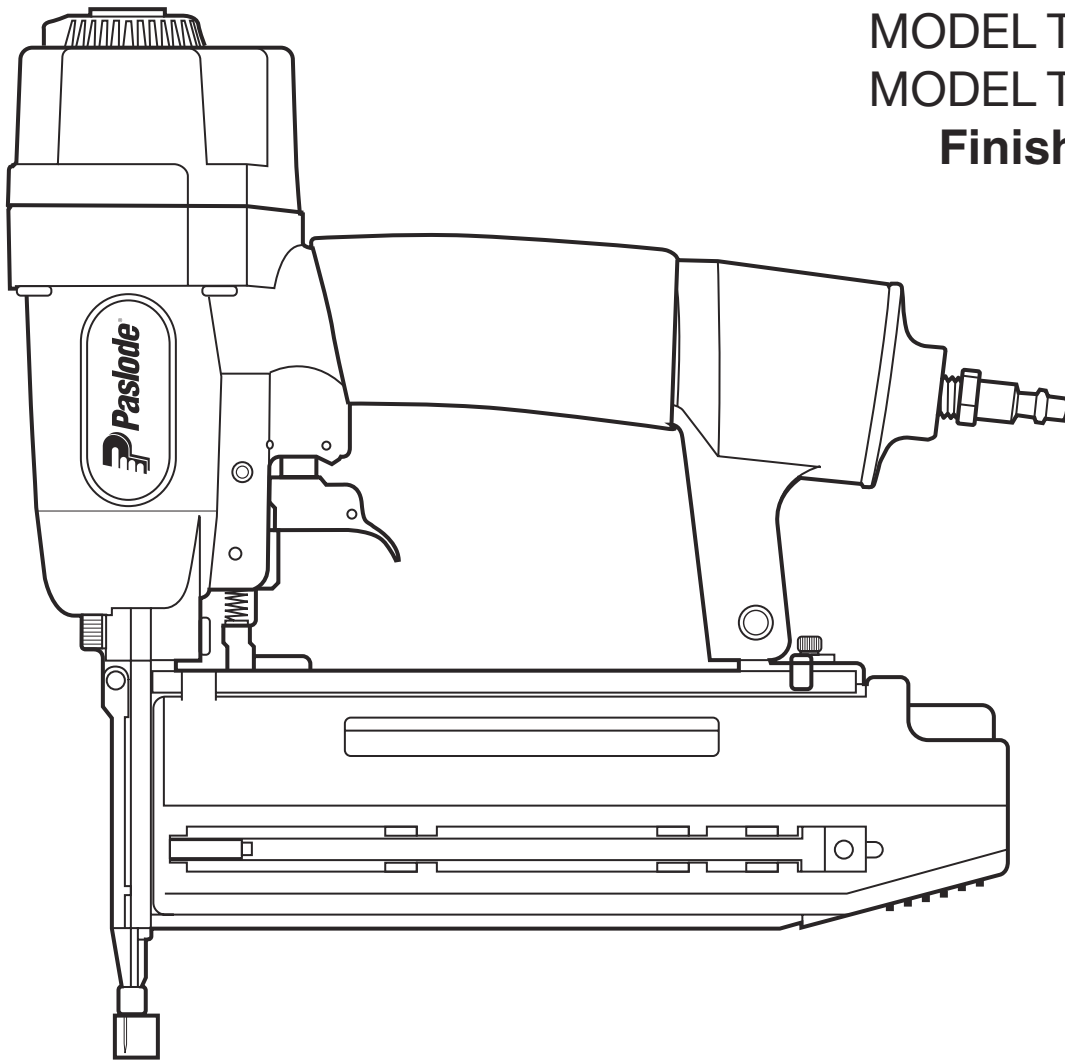

MODEL T200-F18
MODEL T125-F18
Finish Nailers



IMPORTANT!
DO NOT DESTROY

It is the customer's responsibility to have all operators and service personnel read and understand this manual.

**OPERATING MANUAL AND
SCHEMATIC**

INTRODUCTION

The **PASLODE® T200-F18 and T125-F18** finish nailers are quality-built tools designed for use in residential trim applications. These tools will deliver efficient, dependable performance when used according to the manufactures guidelines. Please study this manual including the safety instructions to fully understand the operation of these tools.

TOOL AND FASTENER SPECIFICATIONS	3
SAFETY INSTRUCTIONS	4
INSTRUCTIONS FOR LOADING	5
EXPLODED VIEW AND SPARE PARTS LIST	6
ACCESSORIES	8

TOOL WARRANTY AND LIMITATIONS

Paslode warrants that newly purchased power fastening tools parts and accessories will be free from defects in material and workmanship (excluding wear parts) for the period shown below, after the date of delivery to the original user.

90-DAY LIMITED WARRANTY

A 90-day warranty will apply to all parts, except those which are specifically covered by an extended warranty.

EXTENDED LIMITED WARRANTY FOR ON SITE CONSTRUCTION APPLICATIONS

A one year warranty will apply to all housing and cap assembly castings. A six month warranty will apply to all magazines parts.

NORMAL WEARING PARTS

The following parts are considered normal wearing parts and are not under warranty:

- Bumper
- Drive Blades
- "O" Rings
- Piston Rings

WARRANTY STATEMENT

Paslode's sole liability hereunder will be to replace any part or accessory which proves to be defective within the specific time period. Any replacement part or accessory provided in accordance with this warranty will carry a warranty for the balance of the period of warranty applicable to the part it replaces.

This warranty is void as to any tool which has been subjected to misuse, abuse, accidental or intentional damage, used with fasteners not meeting Paslode specification, size, or quality, improperly maintained, repaired with other then genuine Paslode replacement parts, damaged in transit or handling, or which, in Paslode's opinion, has been altered or repaired in a way that affects or detracts from the performance of the tool.

PASLODE MAKES NO WARRANTY, EXPRESSED OR IMPLIED, RELATING TO MERCHANTABILITY, FITNESS, OR OTHERWISE, EXCEPT AS STATED ABOVE, and Paslode's liability AS STATED ABOVE AND AS ASSUMED ABOVE is in lieu of all other warranties arising out of, or in connection with, the use and performance of the tool, except to the extent otherwise provided for by applicable law. PASLODE SHALL IN NO EVENT BE LIABLE FOR ANY DIRECT, INDIRECT, OR CONSEQUENTIAL DAMAGES, INCLUDING, BUT NOT LIMITED TO, DAMAGES WHICH MAY ARISE FROM LOSS OF ANTICIPATED PROFITS OR PRODUCTION, SPOILAGE OF MATERIALS, INCREASED COST OF OPERATION, OR OTHERWISE.

Paslode reserves the right to change specifications, equipment, or designs at any time without notice and without incurring obligation.

TOOL AND FASTENER SPECIFICATIONS

MODEL NO.	T200-F18 (Part# 500959)	T125-F18 (Part#501161)
HEIGHT	9-3/4"	7-1/2"
WIDTH	2-3/8"	2-3/8"
LENGTH	9-3/4"	9-2/3"
WEIGHT	2.1lbs.	1.75 lbs.
NAIL LENGTH	5/8" - 2"	5/8" - 1-1/4"
SHANK DIAMETER	18 gauge	
OPERATING PRESSURE	70 to 100 p.s.i.	

TOOL AIR FITTINGS:

This tool uses a 1/4" N.P.T. male plug. The inside diameter should be .28" (7mm) or larger. The fitting **must** be capable of discharging tool air pressure when disconnected from the air supply.

OPERATING AIR PRESSURE:

70 to 100 p.s.i. Select the operating air pressure within this range for best tool performance.

DO NOT EXCEED THIS RECOMMENDED OPERATING PRESSURE.

SAFETY INSTRUCTIONS

SAFETY FIRST

These safety instructions provide information necessary for safe operation of Paslode® tools. **DO NOT ATTEMPT TO OPERATE THE TOOL UNTIL YOU READ AND UNDERSTAND ALL SAFETY PRECAUTIONS AND MANUAL INSTRUCTIONS.**



WEAR EYE AND HEARING PROTECTION

Always wear hearing and eye protection devices, that conform to ANZI Z87.1 requirements, when operating or working in the vicinity of a tool. As an employer you are responsible for enforcing the use of eye protection. Wear hard hats in environments that require their use.

THE TOOL MUST BE USED ONLY FOR THE PURPOSE FOR WHICH IT WAS DESIGNED

Do not throw the tool on the floor, strike the housing in any way or use the tool as a hammer to knock material into place.

NEVER ENGAGE IN HORSEPLAY WITH THE TOOL

The tool is not a toy so do not use it like one. Never engage in horseplay with the tool or point it at yourself or any other person, even if you think it is not loaded.

NEVER ASSUME THE TOOL IS EMPTY

Check the magazine for fasteners that may be left in the tool. Even if you think the tool is empty or disconnected, never point it at anyone or yourself. Unseen fasteners could fire from the tool.

NEVER CLAMP THE TRIGGER IN A LOCKED OR OPERATING POSITION

The trigger of the tool must never be tampered with, disabled or clamped in a locked or operating position since this will cause the tool to drive a fastener any time the work contacting element depressed.

DO NOT LOAD FASTENERS WITH THE AIR LINE CONNECTED, OR WITH THE TOOL TRIGGER OR WORK CONTACTING ELEMENT DEPRESSED

When loading fasteners into the tool be sure you disconnect the air line and that you do not depress the trigger or work contacting element.



OPERATE THE TOOL ONLY ON A WORKPIECE

The tool should be operated only when it is in contact with the workpiece. Even then you should be careful when fastening thin material or working near the edges and corners of the workpiece since the fasteners may drive through or away from the workpiece.

DO NOT DISABLE OR REMOVE THE WORK CONTACTING ELEMENT

This tool is equipped with a safety mechanism, called a work contacting element, to help prevent accidental firing. Never tamper with, disable or remove the work contacting element. Do not use the tool unless the work contacting element is working properly. The tool could fire unexpectedly.



CARRY THE TOOL ONLY BY THE HANDLE

Always carry the tool by the handle only. Never carry the tool by the air hose or with the trigger depressed since you could drive a fastener unintentionally and injure yourself or someone else.

DO NOT WEAKEN THE TOOL HOUSING

The tool housing is a pressure vessel and should never be weakened by having your company's name, area of work or anything else stamped or engraved into its surface.

DISCONNECT THE TOOL WHEN PERFORMING REPAIRS AND CLEARING JAMS

Never attempt to clear a jam or repair a tool unless you have disconnected the tool from the air line and removed all remaining fasteners from the tool.

ALWAYS USE THE PROPER FITTING FOR THE TOOL

Only MALE pneumatic type air connectors should be fitted to the tool, so that high pressure air in the tool is vented to atmosphere as soon as the air line is disconnected.

NEVER install FEMALE quick disconnect couplings on the tool. Female couplings will trap high pressure air in the tool when the air line is disconnected, leaving the tool charged and able to drive at least one fastener.



DO NOT EXCEED THE MAXIMUM RECOMMENDED AIR PRESSURE

Operate the tool only at the recommended air pressure. Do not exceed the maximum air pressure marked on the tool. Be sure the air pressure gauge is operating properly and check it at least twice a day.

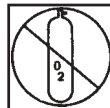

Never use any bottled air or gases such as oxygen to operate the tool since they could cause the tool to explode.

INSPECT TOOL FOR PROPER OPERATION

Clean the tool at least daily and lubricate as required. Never operate a dirty or malfunctioning tool.

USE ONLY PASLODE RECOMMENDED PARTS AND FASTENERS

Use only parts and fasteners specifically designed and recommended by Paslode for use in the tool and for work to be done. Using unauthorized parts and fasteners or modifying the tool in any way creates dangerous situations. Replace all missing warning labels---refer to tool schematic for correct placement and part number.

WARNING

Failure to follow any of the above instructions could result in severe personal injury to tool user and bystanders or cause damage to tool and property.

Contact your local Paslode Representative for presentation of Paslode's Safety Awareness Program

INSTRUCTIONS FOR LOADING

Step No. 1 – Grasp the finish nailer firmly with one hand and press the orange magazine release button at the rear of the magazine and pull the magazine back towards you.

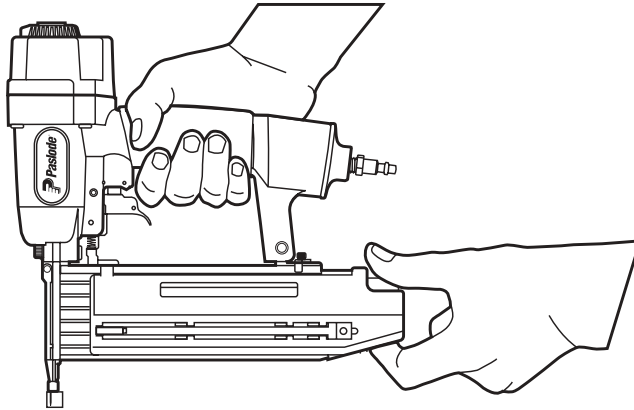

Step No. 2 – Insert the strip of 18 gauge finish nails with the point of the fastener facing down and place the point of the fastener into the **bottom** of the magazine channel. Placing fasteners on the top of the magazine will cause jamming.

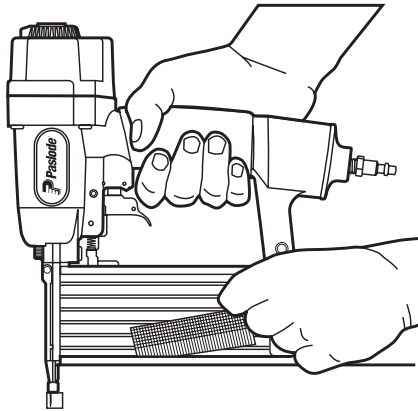

Step No. 3 – Push the magazine firmly towards the front of the tool until it locks in place. The tool is now ready for use.

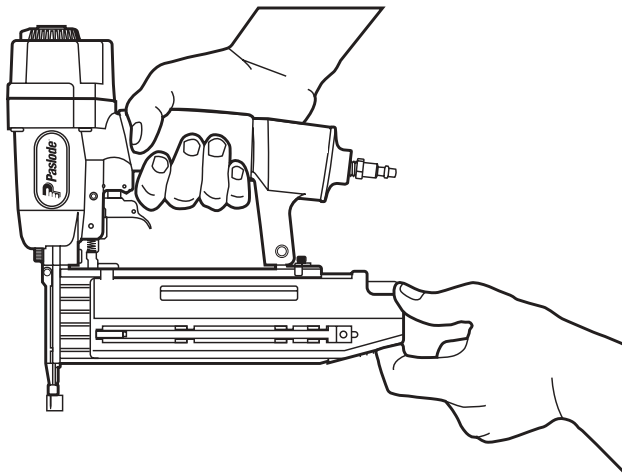

PARTS LEGEND

T200-F18, 500959

T125-F18, 501161

1	500976	1	Deflector	45	501102	1	Stop
2	500977	4	Bolt w/ Flat Washer	46	501103	1	Bracket (T200)
3	500978	1	Hex Soc. Hd. Screw		501187	1	Bracket (T125)
4	500979	1	Cap (T200)	47	501104	1	Follower (T200)
	501170	1	Cap (T125)		501181	1	Follower (T125)
5	500980	1	Seal	48	501105	1	Shaft
6	500981	1	Compression Spring	49	501106	1	Follower Spring (T200)
* 7	500982	1	O-Ring		501183	1	Follower Spring (T125)
* 8	500983	1	O-Ring	50	501107	1	Moveable Magazine (T200)
* 9	500984	1	Head Valve Piston		501182	1	Moveable Magazine (T125)
10	500985	1	O-Ring	51	501108	1	Spring Cover
11	500986	1	Gasket, Cap	52	501109	1	Latch (T200)
12	500987	1	Piston Ring		501184	1	Latch (T125)
* 13	500988	1	O-Ring	53	501110	1	Latch Pin (T200)
* 14	500989	1	Piston Assembly (T200)		501185	1	Latch Pin (T125)
	501171	1	Piston Assembly (T125)	54	501111	1	Lock Spring
15	500990	1	Cylinder (T200)	55	501112	1	Latch Cover (T200)
	501172	1	Cylinder (T125)		501186	1	Latch Cover (T125)
16	500991	1	O-Ring	56	501113	2	Tap Bolt
* 17	500992	1	Cylinder Ring	57	501191	1	W.C.E. Guide
18	500993	1	Bumper	58	501115	1	Roll Pin
19	500994	1	Driver Guide (T200)	59	501192	1	W.C.E. Spring
	501173	1	Driver Guide (T125)	60	501193	1	Upper W.C.E.
20	500995	1	O-Ring	61	501174	1	E-Ring
21	500996	1	Trigger Valve Head	62	501175	1	Interm. W.C.E. (T200)
22	500997	1	Spring		501195	1	Interm. W.C.E. (T125)
23	500998	1	Plunger	63	501120	1	Lower W.C.E. (T200)
→ 24	500999	1	O-Ring		501196	1	Lower W.C.E. (T125)
25	501082	1	O-Ring	64	501121	1	Protective Tip
26	501083	1	Plunger Cap	65	501122	1	Anchor Block
27	501084	2	Roll Pin	66	501123	1	Magazine Spacer
→ 28	501085	1	Trigger Lever	67	501124	1	Lock Spring
→ 29	501086	1	Trigger	68	501125	1	Latch
→ 30	501087	1	Roll Pin	69	501126	1	Flat Washer
31	501088	1	Trigger Pivot Pin	70	501127	1	Hex Soc Hd Bolt
32	501089	2	Urethane Retainer	71	501128	1	Bolt Assembly
33	501090	1	Housing Assembly	72	501188	1	W.C.E. Stop
34	501091	1	Air Plug	73	501130	1	Hex Soc Hd Bolt
35	501092	1	Dust Cover	74	501131	1	Lock Nut
36	501093	2	Bolt Assembly (T200)	75	500492	1	Warning Label (T200)
	501176	2	Bolt Assembly (T125)		501197	1	Warning Label (T125)
37	501094	1	Front Cover	76	501134	1	Magazine Label (T200)
38	501095	1	Front Guide (T200)		501198	1	Magazine Label (T125)
	501177	1	Front Guide (T125)	77	501135	2	Housing Label
39	501096	1	Fixed Pin	78	501189	1	Hex Socket Button Hd Bolt
40	501097	1	Hex Soc Hd Bolt	79	501190	1	Stop
41	501098	1	Back Plate (T200)	80	501194	1	Adjuster
	501178	1	Back Plate (T125)	81	501271	1	O-Ring
42	501099	1	Fixed Magazine (T200)	82	501272	1	End Cap
	501179	1	Fixed Magazine (T125)	83	501273	1	O-Ring
43	501100	1	Flat Bar (T200)	→ 84	219260	1	Insert, Long
	501180	1	Flat Bar (T125)	→ 85	219261	1	Insert, Short
44	501101	2	Bolt Assembly	→ 86	501387	1	Trigger Spring

* Denotes Normal Wear Items.

** Make sure Warning Label (500492 or 501197) is properly affixed.
Replace if necessary.

Label available at no charge through the Service Parts Dept.

▲ Apply Loctite 242 (Blue) Part No. 093500.

→ Denotes Change

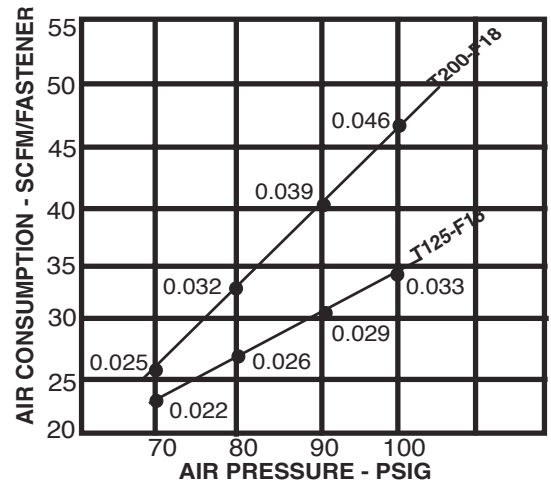

T200-F18

500959

T125-F18

501161

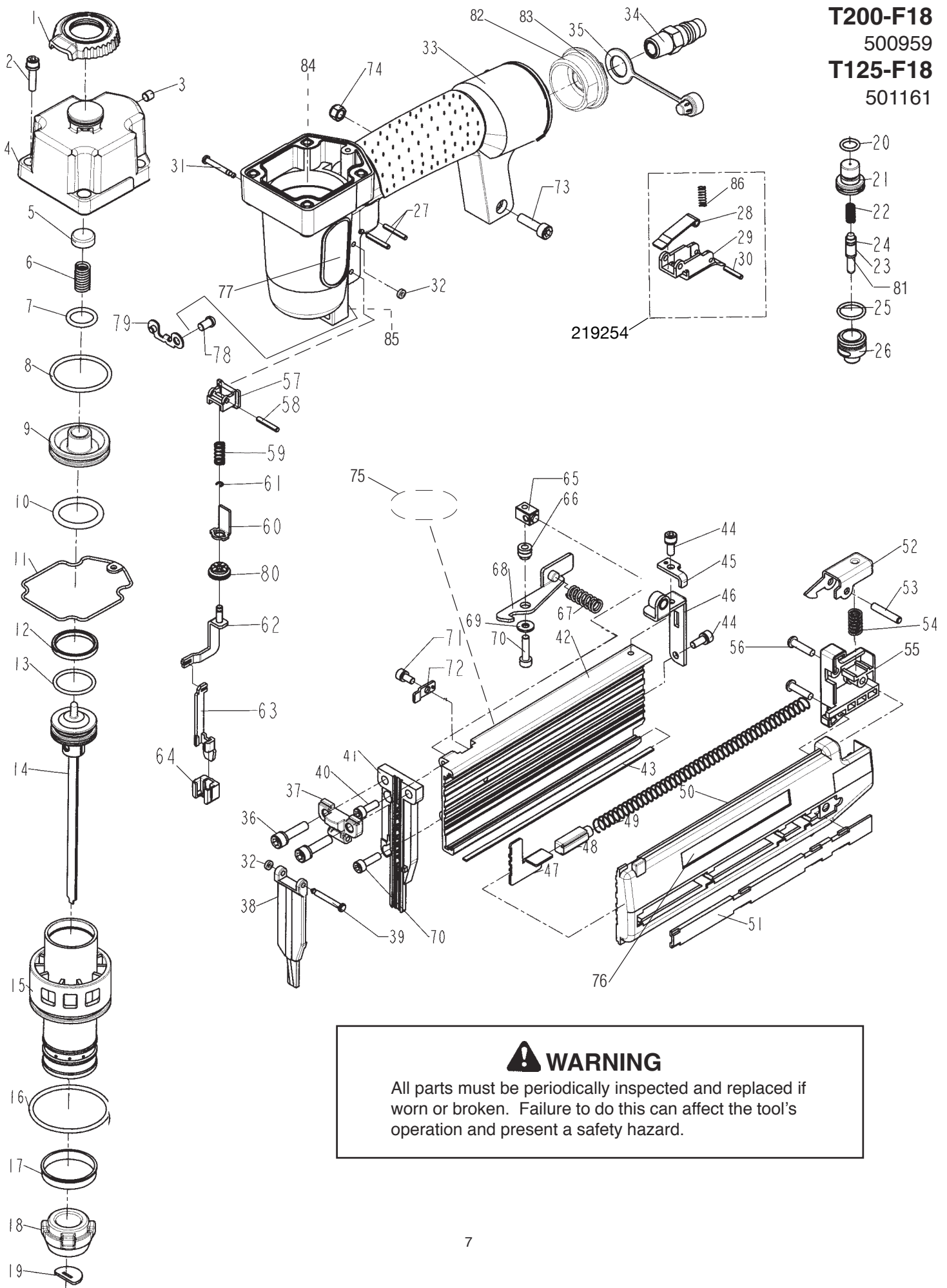

⚠ WARNING
All parts must be periodically inspected and replaced if worn or broken. Failure to do this can affect the tool's operation and present a safety hazard.

ACCESSORIES

Safety Glasses

Clear

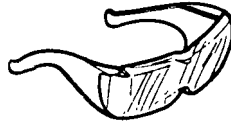

Part No. 402510

Lubricants and Loctite

Loctite 242 (Blue)

Part No. 093500

Lubricating Oil 16 oz.

Part No. 403720

Lubricating Oil with Anitfreeze 8 oz.

Part No. 219090

Chemplex 710 Lubricant 1lb.

Part No. 403734

Degreaser Cleaner

Ideal cleaner for all Paslode tools.

Part No. 219086

Sequential Operating Kit

This special attachment is designed for sequential operation (stops “contact” firing). The operator must depress and hold the work contacting element against the work surface before pulling the trigger. This sequence must be repeated each time the tool drives a fastener.

Part No. 219254

Contact Trip Trigger

This kit allows for successive or “bounce” firing.

Part No. 219265



An Illinois Tool Works Company
888 Forest Edge Drive
Vernon Hills, Illinois 60061-3105