

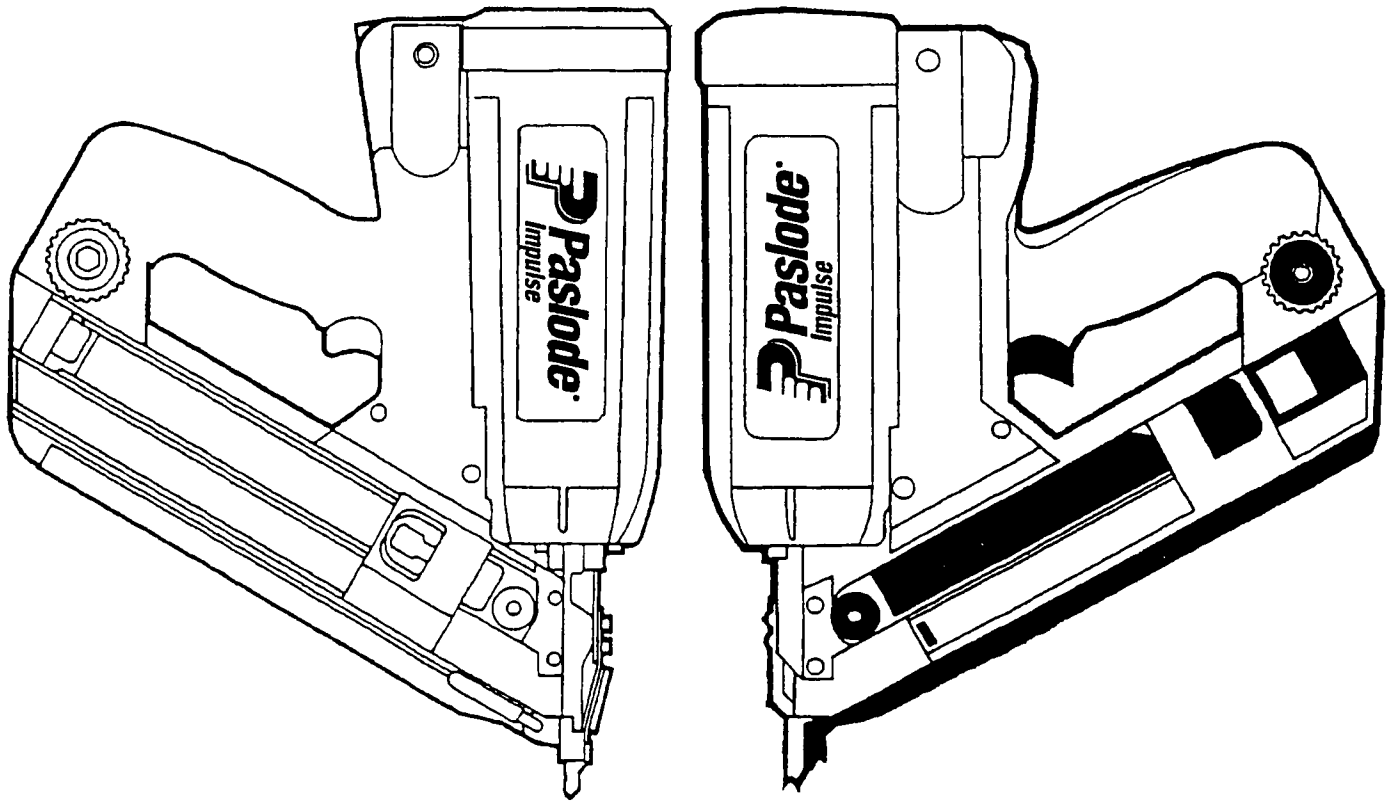

MODEL IM325 FRAMING
MODEL IM325 POSITIVE PLACEMENT
CORDLESS NAILERS



TOOL SCHEMATIC AND PARTS

IMPORTANT!
DO NOT DESTROY

Always refer to Operating Manual#403673 for detailed information on these tools. It is the customer's responsibility to have all operators read and understand this information.

IM325 FRAMING, 404600

PARTS LEGEND

IM325 POSITIVE PLACEMENT, 900129

29774

1	401369	1	Cap Grill	68	401396	1	Cam
2	402268	1	Filter	69	402201	2	Screw, Thread #2x5/8
3	008738	4	Socket Head Cap Screw, #24 x 1-1/4	70	401397	1	Cam Bushing
4	008388	6	Flat Washer, #10	71	900019	1	Handle, Right Side
5	401365	1	Cap Assembly	72	401444	2	Clip Ring (Truarc #5133-12)
6	401481	3	Pan Head Phillips Screw, #8-32 x 3/8	73	401443	1	Pivot Pin
7	900271	1	P.C. Board Assembly	74	401441	1	Follower
8	404611	1	Fan Motor with Connector		900118	1	Follower (POSITIVE PLACEMENT)
9	404397	1	Spark Plug Boot	75	401442	1	Torsion Spring
→ 10	900286	1	Spark Plug Assembly, incl. O-Ring	76	401439	1	Follower Handle
*11	091623	1	O-Ring	77	401490	1	Screw, Thread Forming, #6 x 5/8
12	401356	1	Sleeve, Motor	78	402338	1	Retaining Washer
13	401345	1	Motor Mount Assembly	79	401494	1	Wave Washer
14	401355	1	Motor Retaining Ring	80	091998	1	Flat Washer, 1/4
15	404601	1	Head Switch Assembly	81	401485	1	Knob Assembly
16	401340	1	Stem Adapter	82	401409	1	Thread Forming Screw, #6-32 x 1/2
17	401336	1	Cylinder Head, Machined	83	401436	1	Magazine Cover
18	403992	1	O-Ring	84	402332	1	Magazine Channel, 3-1/4
→ 19	403167	1	Fan Blade Assembly	85	401410	4	Machine Screw, #6-32 x 1/2
20	401313	1	Air Dam	86	401434	1	Spring, Lockout
21	900235	1	Combustion Chamber Assembly	87	401493	1	Negator Hub
22	401330	1	Chamber Lockout Bar	88	401432	1	Constant Force Spring
23	401328	1	Piston Stop Retaining Ring	89	401430	1	Washer, Negator
24	401461	2	Piston Ring	90	006443	2	Internal Tooth Lockwasher, #6
25	401325	1	Piston and Driver Blade Assembly	91	403116	1	Instruction Label
	900228	1	Piston and Driver Blade Assembly (POSITIVE PLACEMENT)	92	401435	1	Lockout Cover
*26	403532	1	Bumper	93	401433	1	Lockout Bracket
*27	404482	1	O-Ring	94	900042	1	Magazine, Left Side with Label
28	403083	1	Sleeve and Mid-Check Ring Assembly		900168	1	Magazine, Left Side with Label (POSITIVE PLACEMENT)
29	401320	1	Seal Washer	95	401428	1	Nose Plate
30	401321	2	Wave Washer		900075	1	Nose Plate (POSITIVE PLACEMENT)
31	401322	1	Mid-Check Retaining Ring	96	401418	2	Guide Pin
32	401488	1	Spring	97	401408	1	Nail Channel
33	900234	1	Cage		900087	1	Nail Channel (POSITIVE PLACEMENT)
34	092769	4	Screw, #10-32x1/4	98	401419	1	Cover Plate
35	401489	1	Grommet		900088	1	Cover Plate (POSITIVE PLACEMENT)
36	401378	1	Upper Probe	99	900230	1	Washer
37	401376	1	Nose Flange	100	401421	1	Battery Contact
38	900198	2	Pin, Header Coil	101	402327	1	Magazine, Right Side
	009074	1	Roll Pin (POSITIVE PLACEMENT)		900090	1	Magazine, Right Side (POSITIVE PLACEMENT)
39	401380	1	Tie Bar	102	401422	1	Battery Clip
40	401499	1	Nose	103	401423	1	Machine Screw, #6-32 x 1-1/4
	900077	1	Nose (POSITIVE PLACEMENT)	104	900012	1	Cover Plate, Wire
41	004224	2	Socket Head Cap Screw, #10-32 x 3/8	105	900013	1	Lever, Switch
42	004238	5	Lockwasher, #10	106	006562	9	Washer, #8
43	401379	1	Work Contacting Element Assembly	107	404390	2	Label, Housing
	900201	1	Work Contacting Element Assembly (POSITIVE PLACEMENT)	108	013625	4	Socket Head Cap Screw, #8-32 x 1/2
44	900010	1	Housing	→ 109	401478	1	Warning Label
45	401371	1	Nose Retaining Ring	110	900202	1	Nose Plate Assembly
46	900296	3	Screw, #10-24 x 1	111	404610	1	Nameplate
→ 47	900480	1	Spark Plug Wire	112	900117	1	Lever (POSITIVE PLACEMENT)
→ 48	900280	1	Spark Unit Assembly	113	900224	1	Label, Instruction (POSITIVE PLACEMENT)
49	404619	1	Insulator	114	900130	1	Handle (POSITIVE PLACEMENT)
50	404490	1	Trigger/Switch	115	900124	1	Plunger (POSITIVE PLACEMENT)
51	403999	1	Contact Board with Connector	116	900223	1	Knob (POSITIVE PLACEMENT)
52	401405	4	Nut, #6-32	117	900126	1	Spring (POSITIVE PLACEMENT)
53	401400	1	Actuator	118	900131	1	Retaining Ring (POSITIVE PLACEMENT)
54	404433	1	Pin	119	900133	1	Label, Short-Long Nail (POSITIVE PLACEMENT)
55	404432	1	Bushing, Actuator	120	900081	1	Work Contacting Element
56	404622	1	Handle, Left Side with Label	121	900220	1	Bracket, Probe
57	401404	5	Flat Washer, #6	122	900221	1	Probe
58	401403	3	Screw, #6-32x1	123	900222	1	Pin, Probe
59	006546	3	Internal Tooth Lockwasher, #10	124	900196	1	Retaining Ring, Probe Pin
60	900233	3	Screw, # 10-32 x 9/16	125	900197	2	Screw #8-32 x 5/16 Button Head
61	401495	1	Belt Hook	126	006562	4	Internal Lock Washer
62	401406	1	Screw, #6-32 x 1-1/12	127	091880	1	Roll Pin, Knob
63	401450	3	Pad	128	900182	2	Washer
64	404385	1	LED Lens	129	900184	1	Label, Danger Sign
65	401395	1	Trigger Spring	130	401416	1	Nose Plate, Right Side
66	401394	1	Trigger				
67	401479	1	Pin				

* DENOTES NORMAL WEAR ITEM

** MAKE SURE WARNING LABEL (401478) IS PROPERLY AFFIXED, REPLACE IF NECESSARY. LABEL AVAILABLE AT NO CHARGE THROUGH THE SERVICE DEPARTMENT.

→ DENOTES NEW CHANGE

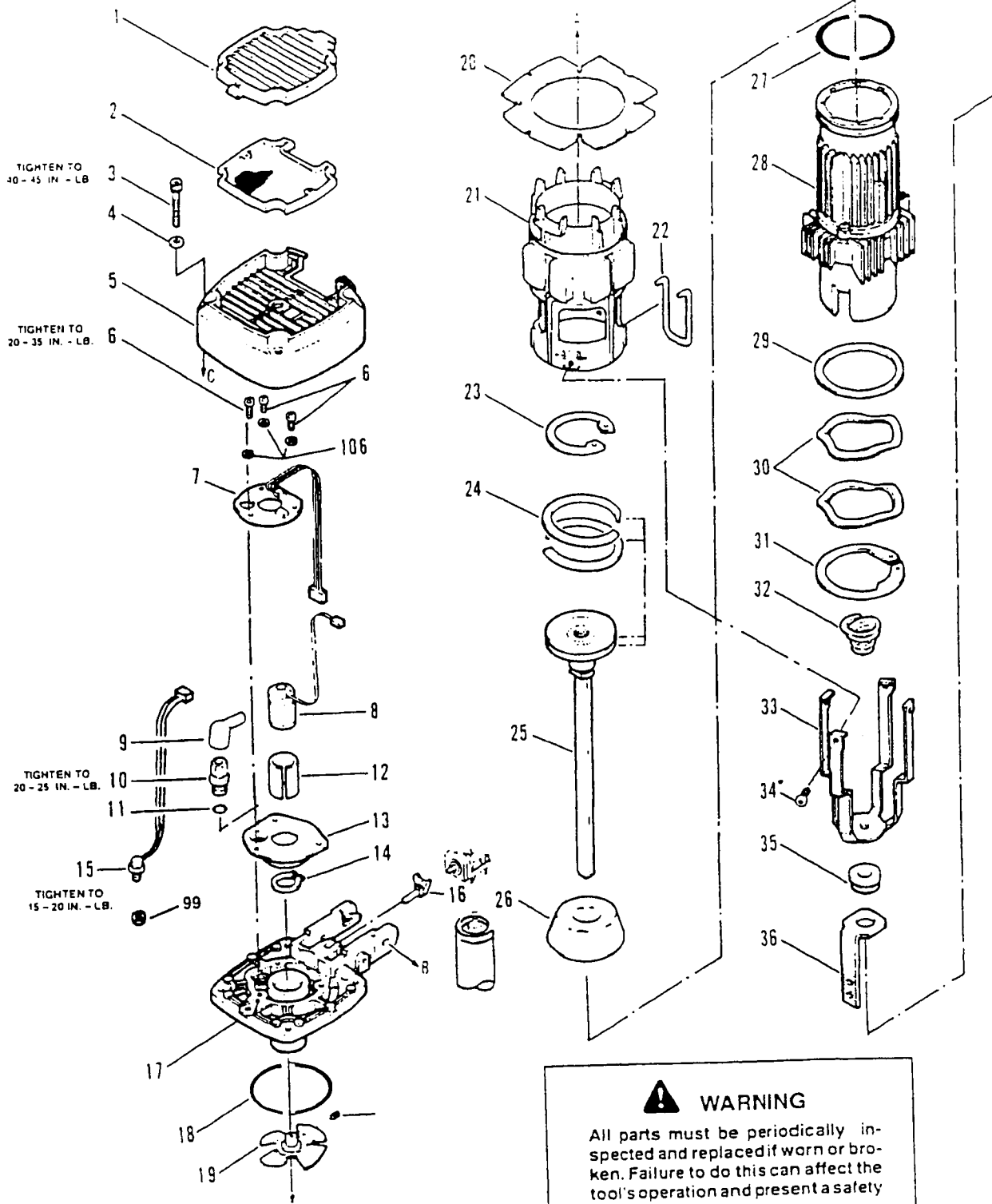

IM325 FRAMING, 404600
 IM325 POSITIVE PLACEMENT, 900129

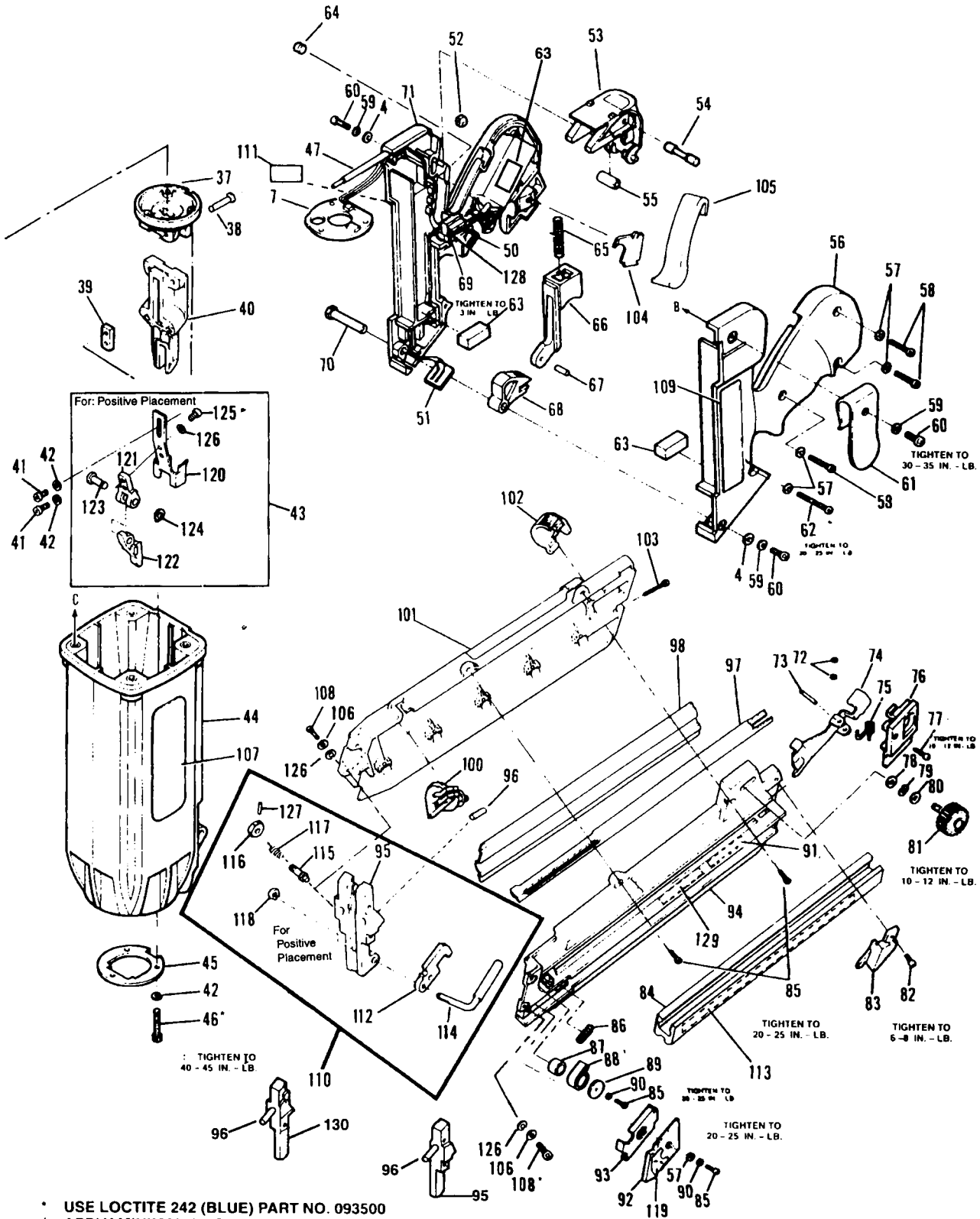

* USE LOCTITE 242 (BLUE) PART NO. 093500
 † APPLY MINIMAL AMOUNT

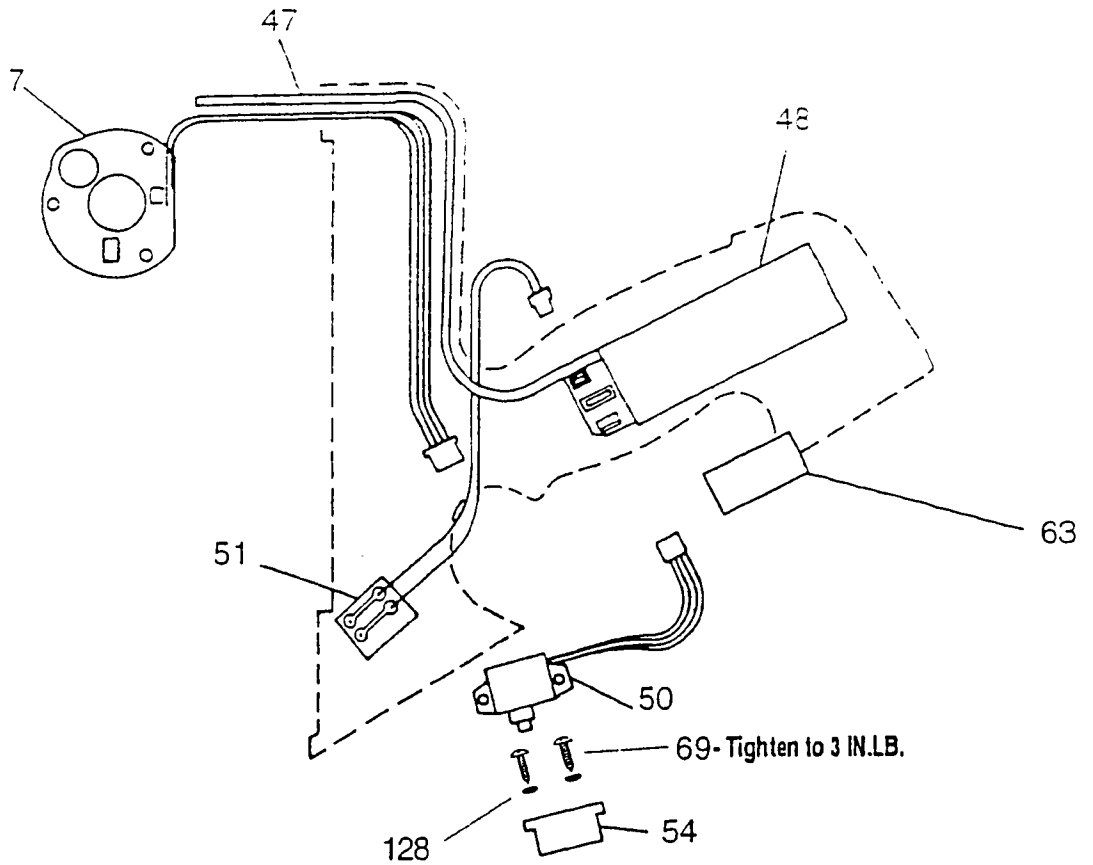

SAFETY INSTRUCTIONS

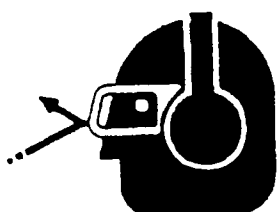
	<p>⚠ DANGER</p> <p>Always wear EYE and EAR safety gear when working with or in the vicinity of the Impulse® nailer.</p>
---	--

	<p>⚠ DANGER</p> <p>The Impulse® nailer should be operated only when it is in contact with the work surface. When fastening thin materials such as plywood, be sure to position the tool so that the fastener is driven into the underlying piece.</p>
---	--

1. WEAR EYE AND EAR PROTECTION.
2. ALWAYS ASSUME THE TOOL IS 'LOADED'.
3. OPERATE THE TOOL ONLY ON THE WORK SURFACE.
4. NEVER REMOVE OR DISABLE THE WORK CONTACTING ELEMENT.

This device helps reduce the possibility of accidental fastener discharge by preventing the tool from operating until it is completely against the work surface. NEVER operate the tool if the work contacting element is not working properly.

5. ALWAYS POINT THE TOOL AWAY FROM YOURSELF AND OTHERS WHEN CLEARING JAMS OR REMOVING FASTENERS.

Pull the follower back and latch. Tip the tool nose up slightly and fasteners should slide out of the magazine. If fasteners are jammed, refer to the appropriate section of the operating manual.

6. NEVER ATTEMPT TO OPERATE THE TOOL IF PARTS ARE LOOSE, DAMAGED OR MISSING.

ACCESSORIES

Impulse Nailer Case

Part No. 403741

No-Mar Work Contact Element

Rubber tipped WCE to eliminate marring work surface.
(Replacement rubber tip, Part No. 403369)

Part No. 402502

Battery Cell

Part No. 402500

Impulse Oil

Part No. 401482

Magazine Assembly Kit

This kit includes a framing magazine and a framing W.C.E.
to convert a Positive Placement tool into a Framing tool.

Part No. 219207

Battery Charger Kit

(Replacement Charger Base Only - Part No. 900291)
(Replacement Transformer Only - Part No. 900292)

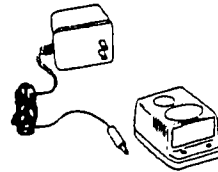

Part No. 900200

Safety Glasses

Clear
Tinted

Part No. 402510

Part No. 402512

Degreaser Cleaner

Ideal cleaner for all Paslode tools.

Part No. 219086

Magazine Channel 3-1/2"

Use to convert IM325 Solid State to drive 3-1/2" nails.
(Soft woods only)

Part No. 402333

Service Tool Kit

A 19 piece tool kit containing all the necessary tools to
repair any Impulse Tool.

Part No. 401498

IM325 Solid State Cleaning Procedure

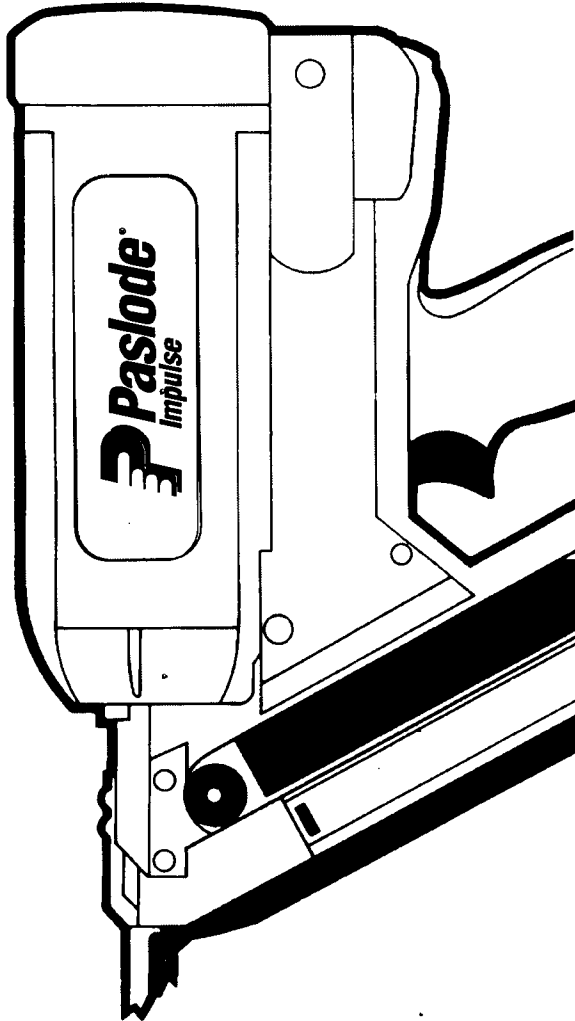

This procedure provides a simple but effective way to clean your Impulse® Cordless Nailer and maintain reliable operation. Regular cleaning and lubrication will also extend part life and provide maximum nail driving power.

Only two tools are necessary to disassemble the Impulse Cordless Nailer in preparation for cleaning: a #2 Phillips screwdriver, and the 5/32" hex socket wrench provided with the Impulse Cordless Nailer.

Paslode recommends that an aerosol "Safety Cleaner", such as Paslode Safety Cleaner (Part No. 219086), be used for cleaning. This cleaner is available through your local Paslode Dealer.

If a different type of Safety Cleaner is selected, make sure that it will not damage rubber. Both of the O-Ring seals in the area that will be cleaned are made of a rubber compound. Chemical damage to these O-Ring seals may result in the tool being made inoperable.

To begin, you will need the following items:

Tools

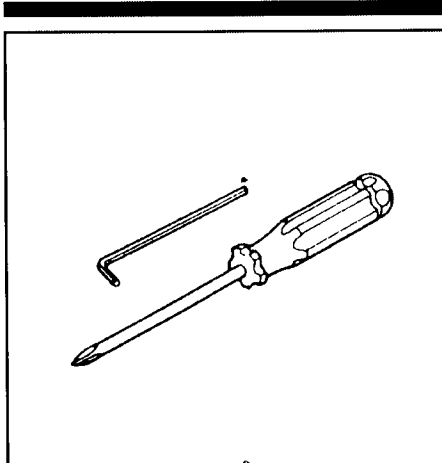

Safety Cleaner

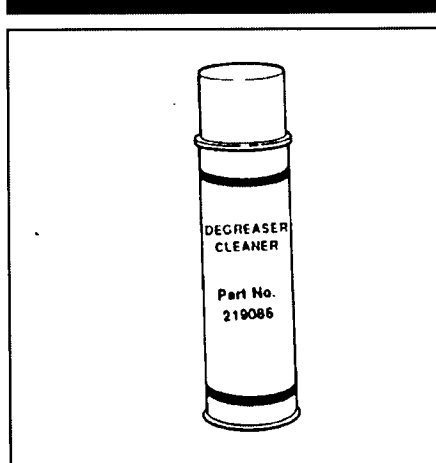

Impulse Oil

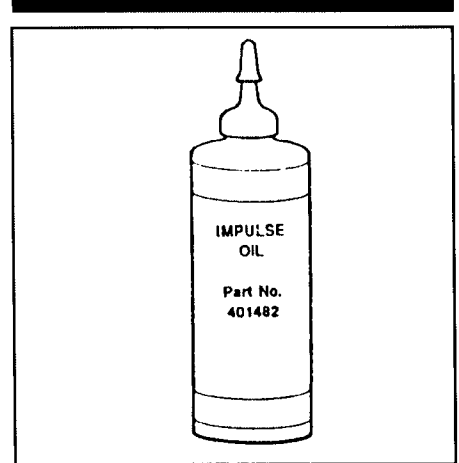

Tool Disassembly

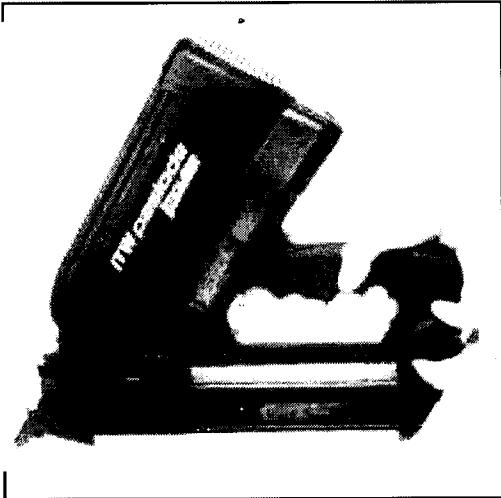

DANGER

Remove all fasteners, fuel, and battery prior to servicing tool.

Magazine Assembly

Step 1

Remove the **MAGAZINE ASSEMBLY** by loosening and removing the **Locking Knob**. Make sure the three washers remain in place on the **Locking Knob**. The **Wave Washer** should be *between* the two **Flat Washers**.

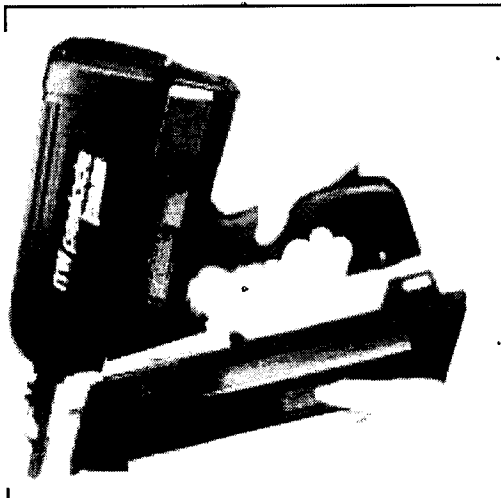

Slide the **Magazine** back and away from the **Nose** to remove it, and set aside.

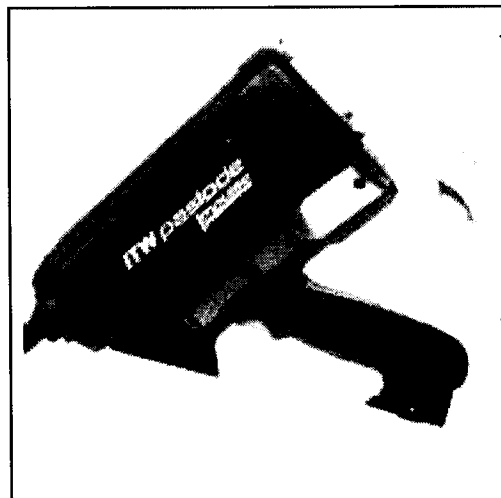

Handle Assembly

Step 2

Using the 5/32" Hex Key Wrench (#401331), unscrew four #10-24 x 1-1/4" long **Socket Head Cap Screws** and **Washers** from the **Cap Assembly** on top of the **Motor Assembly**. Leave the screws in the **Cap Assembly** to avoid loss.



DANGER

Never operate the Impulse tool unless all four Socket Head Cap Screws are firmly tightened on the cylinder head. Failure to do this could result in tool damage, fire and personal injury.

Tool Disassembly

Step 3

Remove the **Cap, Filter,** and **Grill** as one assembly, and set aside. The **Filter** may be removed by lifting the **Grill** off the **Cap**. Clean the **Filter** with a Safety Cleaner, or replace if necessary.

Reassembly Note:

When reassembling the tool, make sure that the **Cap Assembly** does not pinch the exposed wires. **Cap Screws** must be tightened securely!

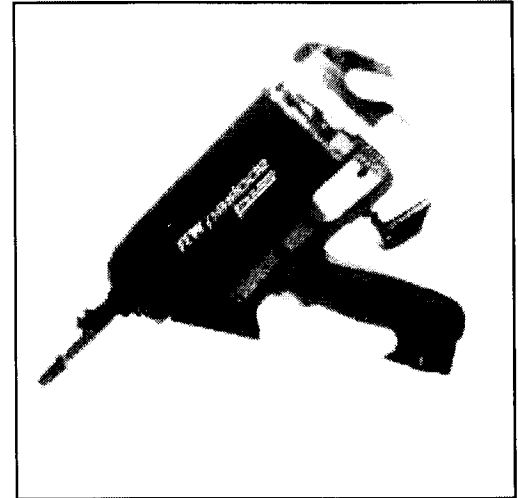

Step 4

Using a Phillips #2 screwdriver, remove the #10-32 x 9/16" long Machine Screw from the lower left side of the **Handle**. The Internal Tooth Lockwasher should be kept on the screw under the head, followed by the Flat Washer.

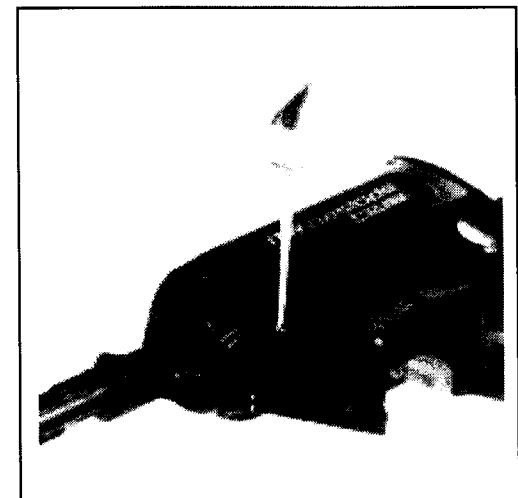

Step 5

Use the screwdriver to push out the **Cam Bushing** from the **Handle Assembly**.

Reassembly Note:

When reassembling the tool it may be helpful to use the screwdriver to align the hole in the nylon **Cam** with the holes in the **Handle Assembly** before attempting to insert the **Cam Bushing**.

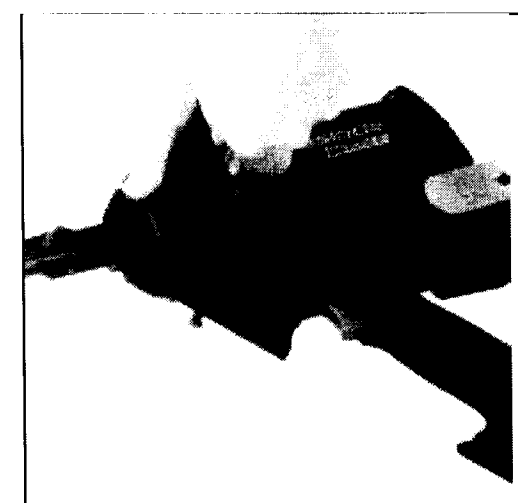

Tool Disassembly

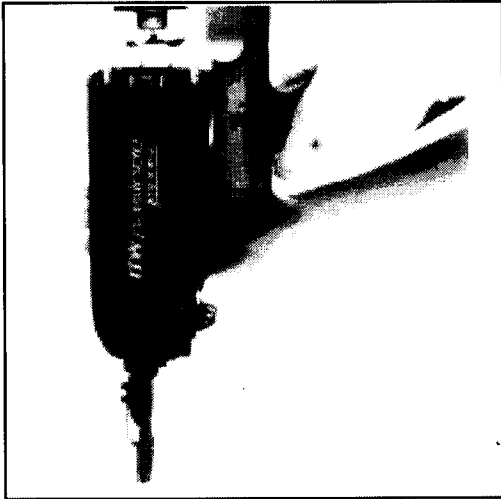

Motor Assembly

Step 6

Gently pull the **Handle** away from the **Motor Assembly** and lift it up and away until the **Fan** clears the **Combustion Chamber Assembly**. **CAUTION:** Use care to ensure that the **Fan** does not scratch the **Combustion Chamber**. Also, be careful when setting the **Handle Assembly** down so that you do not damage the **Fan Blades** or bend the **Fan Motor Shaft**. Note the position of the nylon **Cam** in the lower portion of the **Handle Assembly**, and make sure the **Cam** is in the correct position when reassembling the tool.

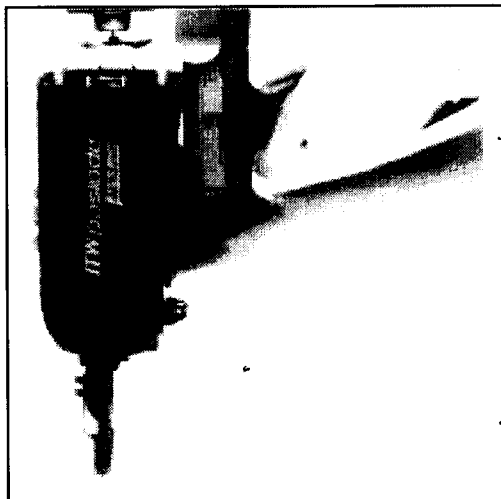

You have now separated the tool into the three major assemblies, allowing access to the areas that require periodic cleaning and lubrication.

Cylinder Head

Step 1

Grasp the **Cylinder Head O-Ring** with the thumb and index finger of one hand, and pull the **O-Ring** out of the groove slightly by applying light pressure while pulling.



Step 2

Grasp the protruding portion of the **O-Ring** with the other hand, and gently pull the **O-Ring** out of the groove and over the fan. Wipe the **O-Ring** clean with a soft, lint-free cloth. Spray Safety Cleaner on the cloth to help remove any sticky residue from the **O-Ring**.



Step 3

Spray the **Cylinder Head** with Safety Cleaner. Allow the dirt and debris to drip off. **DO NOT LET DIRTY CLEANER RUN INTO THE HANDLE!**



Cylinder Head

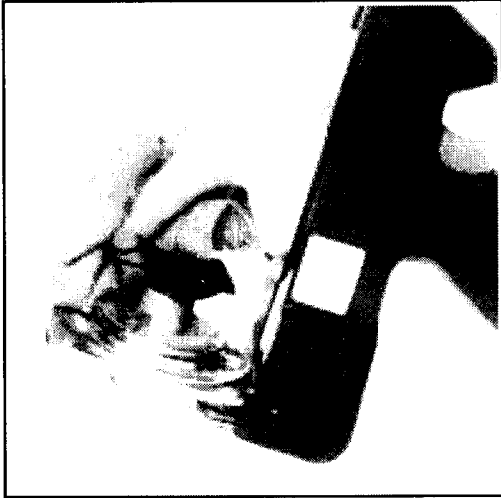

Step 4

Using a clean, lint-free rag, wipe off any remaining cleaner or dirt. Make sure the **O-Ring Groove** and **Spark Plug** are completely clean and clear of debris. Repeat Step 3 to remove any heavy deposits or remaining residue.

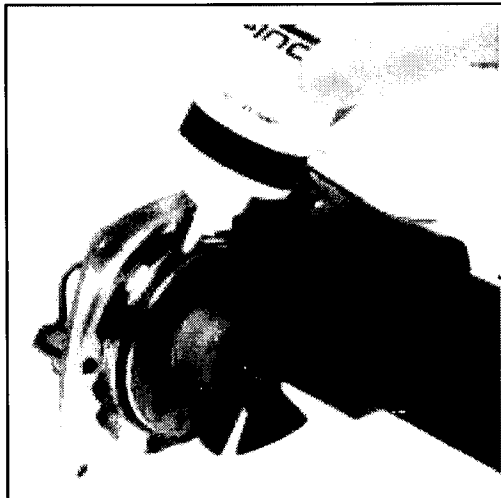

Step 5

Reinstall the **O-Ring**, and lightly lubricate with Paslode **Impulse Oil**, part #401482. Make sure oil is applied evenly around entire **O-Ring**. Set the **Handle/Cylinder Head Assembly** aside.

Note:

Paslode Impulse Oil is specially formulated for use in the **Impulse Tool**. The use of other types of lubricants may cause rapid build-up of combustion residue or result in premature part failure.

Motor Assembly

Step 1

Push the **Piston Assembly** to the "down" position using the handle portion of the screwdriver or a clean piece of wood.

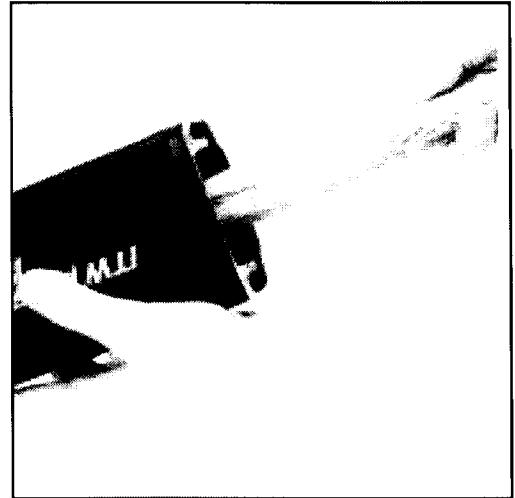

Step 2

Spray a liberal amount of Safety Cleaner into inside of **Sleeve** and **Combustion Chamber**. Invert **Motor Assembly**, and let excess cleaner and dirt drain out.



Step 3

Using a clean area of a lint-free rag, wipe off any remaining cleaner or dirt. Repeat Step 2 to remove any heavy deposits or remaining residue.

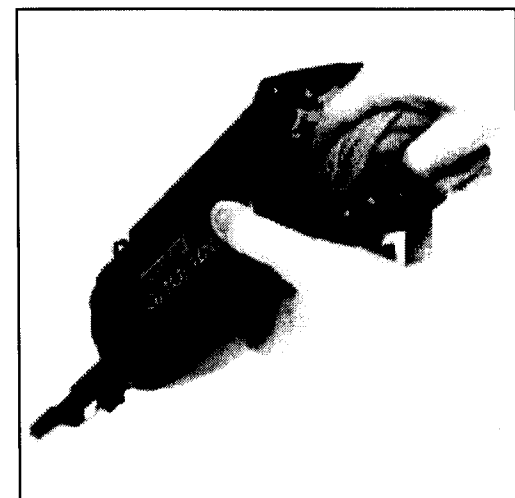

Motor Assembly



Step 4

With **Motor Assembly** tilted up, squeeze 8-10 drops of oil into **Sleeve** (Area "A") and 5-6 drops onto lower lip of **Combustion Chamber** (Area "B"). Rotate **Motor Assembly** while oiling to ensure oil is evenly distributed around **Sleeve** and lip. See **Tool Cut-away Illustration**, page 9.

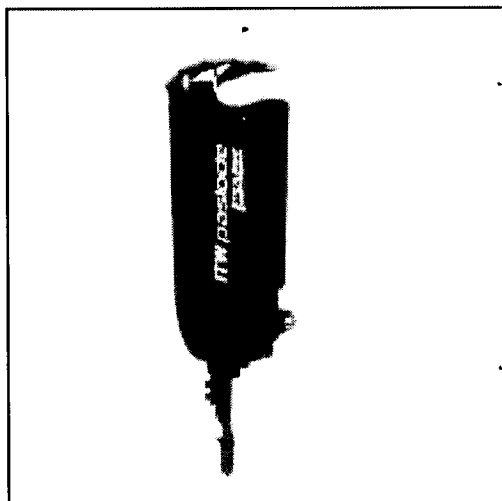

Step 5

Hold **Motor Assembly** upright, and push down and release several times to allow oil on lower lip of **Combustion Chamber** to be evenly distributed.

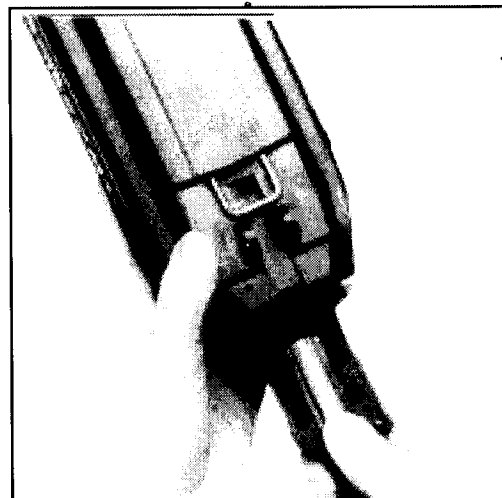

Step 6

Manually push the **Driver Blade** up and down to distribute the oil in the **Sleeve** evenly.

Motor Assembly

Step 7

Tilt the **Motor Assembly** upright, and apply 6-8 drops of **Impulse Oil** evenly spaced around the top of the **Combustion Chamber** (Area "C"). Spread the oil using your fingertip.

Step 8

Reassemble the Impulse following disassembly Steps 1-6, pages 2-4 in **Reverse** order.

DANGER! Do not attempt to operate the tool unless the cap assembly is securely attached to the housing. Operating the Impulse with a loose or missing cap assembly can result in the escape of burning gases, tool damage, and injury to tool user and property.

NOTE: After the tool is completely assembled and all screws are tightened, test the tool for proper operation. Some smoke may be noticeable from the exhaust ports on the first few cycles as excess oil is burned off. Consult the owners manual for instructions if the tool malfunctions.

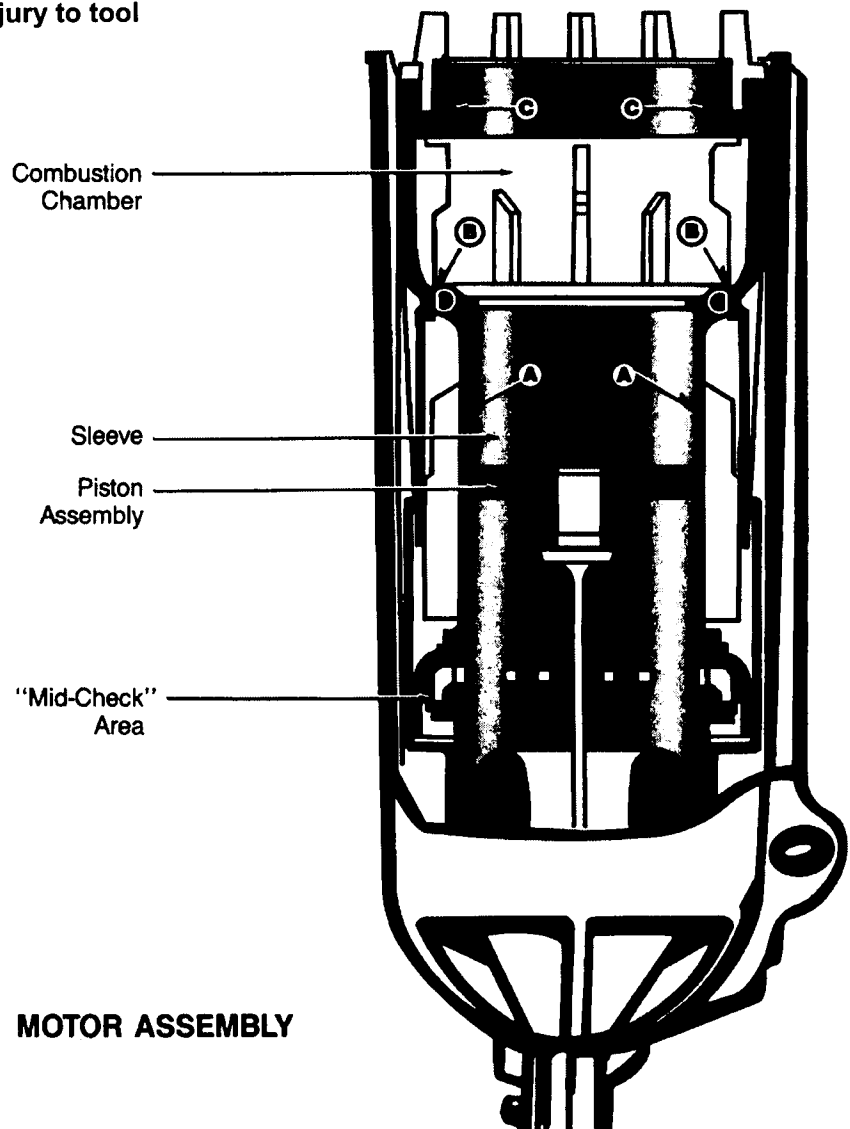

IM325 Solid State Cleaning Procedure

Operating Conditions	Very Dirty	●	●	★	★	★	
	Dirty	●●	●●	●	●	●	
	Moderate	▲	▲	●	●	●	
	Clean	■	■	▲	▲	▲	
		0	2M	6M	8M	8M	10M
		Fasteners Driven/Week					

CLEANING INTERVAL

- ★ 2-3 Days
- Weekly
- Every 2 Weeks
- ▲ Monthly
- Every 2 Months

The maintenance interval for cleaning the **Impulse IM325 Solid State** will vary depending upon the number of nails driven per week, and the operating conditions under which the tool is used. When the **Impulse** is used in a dirty environment or at high nailing rates for extended periods, cleaning should be performed at shorter intervals.

Paslode has developed this chart as a guideline to assist you in establishing the proper cleaning schedule for the type of use the tool is getting. If you find that the suggested cleaning interval is allowing the tool to become excessively dirty between cleanings, reduce the interval to the next shorter frequency. If it is apparent that the **Impulse** is not in need of cleaning at the scheduled time, increase the interval to the next longer period.

If you have any questions regarding this chart or any of the instructions in this cleaning procedure, contact your Paslode distributor for assistance.

Paslode
An Illinois Tool Works Company
888 Forest Edge Drive
Vernon Hills, Illinois 60061

www.paslode.com