

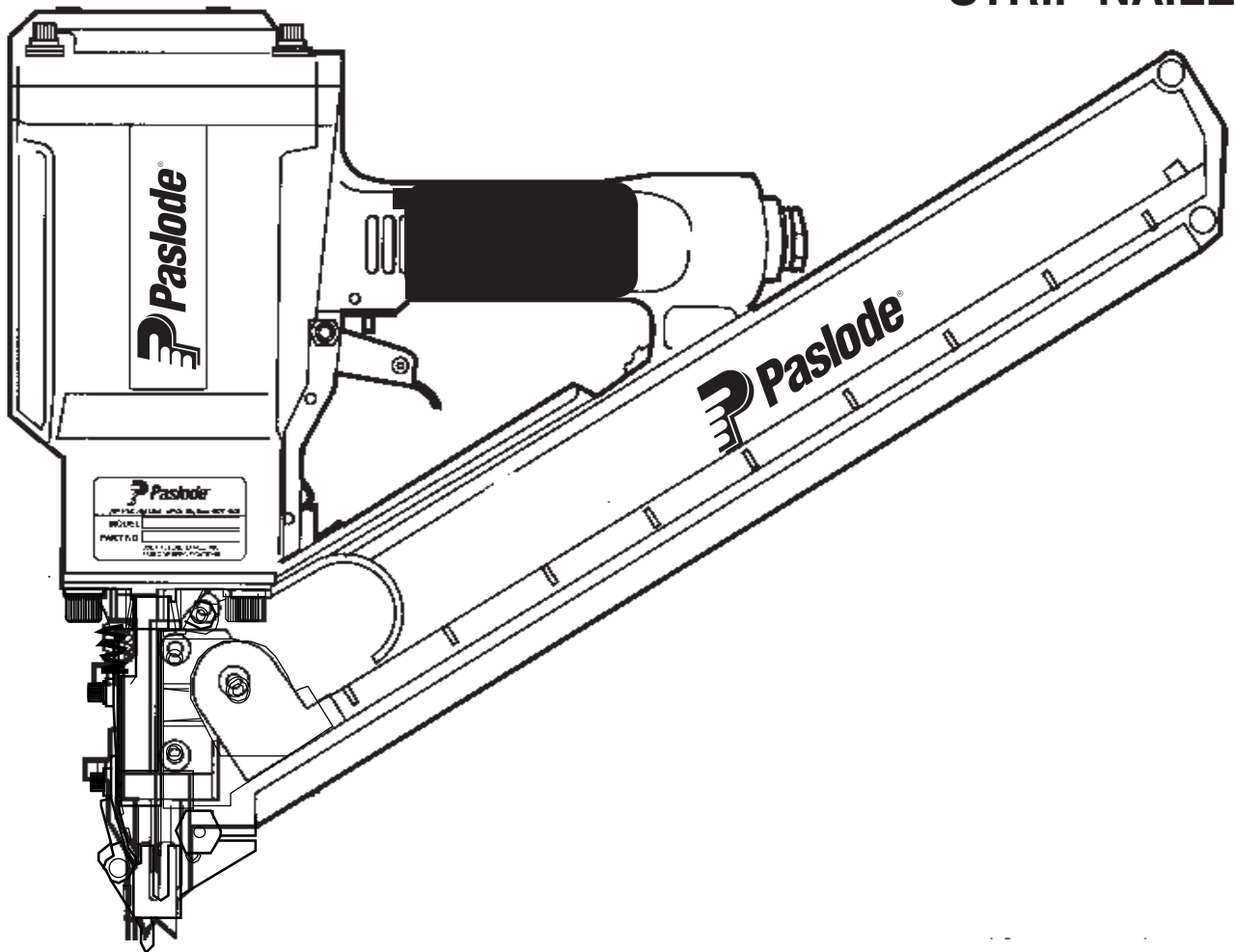

**MODEL 5250/65S-PP
POSITIVE PLACEMENT
STRIP NAILER**



**IMPORTANT!
DO NOT DESTROY**

Always refer to safety and maintenance manual #403606 for detailed information on this tool. It is the customer's responsibility to have all operators and service personnel read and understand this information.

TOOL SCHEMATIC AND PARTS

PARTS LEGEND

5250/65S-PP, 500570

▲ 1	013625	7	Socket Head Capscrew, #8-32 x 1/2"
2	401955	8	Flat Washer, #8
**3	402057	1	Air Deflector
4	500453	1	Bumper, Post
7	092735	4	Socket Head Capscrew, 1/4-20 x 1-1/4"
8	002187	4	Lock Washer, 1/4"
9	092757	4	Flat Washer
10	500452	1	Cap
*11	401983	1	Gasket
12	500407	1	Spring
13	406041	1	Retaining Ring
*14	500461	1	"O" Ring, Upper Valve Piston
15	500455	1	Upper Valve Piston
16	401946	1	Seal, Main Valve
*17	092042	1	"O" Ring, Lower Valve Piston
*18	091208	1	"O" Ring, Lower Valve Piston
*19	401950	1	"O" Ring, Lower Valve Piston
20	500456	1	Lower Valve Piston
21	500454	1	Post
22	095432	1	"O" Ring, Post
▲ 23	402906	1	Button Head Capscrew, #10-32 x 5/8"
25	091861	1	Nut
26	092116	1	Washer
*27	092971	1	"O" Ring, Piston
28	401956	1	Piston
*29	401904	1	Driver Blade
30	402011	1	Seal, Sleeve
31	500860	1	Sleeve
*32	092762	1	"O" Ring Upper, Sleeve
*33	091024	1	"O" Ring Lower, Sleeve
34	401984	1	Flange
34A	402993	1	Shim
*35	401985	1	"O" Ring, Flange
*36	404768	1	Bumper
37	401936	1	Housing
38	404937	2	Logo, Housing
39	097748	1	Spring, Valve Pin
40	097746	1	Valve Pin
*41	092174	1	"O" Ring, Valve Body
42	401958	1	Valve Body
43	026133	3	Roll Pin, 1/8" Dia. x 1" Lg.
44	401992	1	Spring, Interm. Work Contacting Element
45	401991	1	Intermediate Work Contacting Element
46	096893	1	Name Plate
47	402079	1	Trigger Pin
48	404325	4	Stop Nut
50	406006	1	Sequential Trigger Assembly
51	500856	2	Socket Head Capscrew #8-32 x 3/8"
53	406026	4	Cup Washer, Diffuser
▲ 54	401940	1	End Plug
55	091622	1	Reducing Pipe Bushing
56	401997	1	Cup, Knob
57	401996	1	Spring, Knob
58	401993	1	Knob
59	401998	1	Mounting Insert
*60	402008	1	Gasket, Nose Flange
61	402005	1	Flange, Nose
62	006787	2	Roll Pin, 3/16" Dia. x 1" Lg.
62A	401697	2	Roll Pin
63	401988	1	Spring, Work Contacting Element
64	500585	1	Lower W.CE. Bracket
65	402094	2	Flat Washer, #10
66	004238	1	Lock Washer, #10
▲ 67	009037	2	Socket Head Capscrew, 10/32 x 1/2"
68	500577	1	Work Contacting Element
69	402095	1	Nut Bar
70	500575	1	Nose
71	009016	4	Socket Head Capscrew, 5/16-18 x 1"
72	095417	4	Lock Washer, 5/16"
73	002442	4	Lock Washer, #8
74	500948	1	Cover, Magazine
75	401978	1	Spring, Upper Work Contacting Element
76	401977	1	Upper Work Contacting Element
77	402010	2	Bushing
78	500627	4	Socket Head Capscrew 8-32 x 1/2"
79	500580	1	Magazine, Right and Left(Includes Part# 401980)
80	900220	1	Bracket, Probe
81	500584	1	Shear Block (Including Pin)
82	401975	2	Pin, Shear Block
83	500862	1	Follower Assembly
84	900222	1	Pin, Probe
85	900221	1	Probe
86	401965	1	Drum, Negator
*87	401964	1	Spring, Negator
88	403042	1	Cover, Spring
89	008731	1	Socket Head Capscrew, #10-24 x 3/4"
90	016343	2	Socket Head Capscrew, #8-32 x 1-1/4"
91	403738	1	Pin, Magazine
92	403739	1	Spring, Magazine Pin
93	023766	1	Retainer Ring
94	500630	1	Socket Head Capscrew, #8-32 x 1"
95	500576	1	Channel
97	500581	1	Spacer, Magazine
98	091591	1	"O" Ring, End Plug
99	401974	4	Screw, Wear Plate
100	404046	1	Wear Plate Kit
101	900196	1	Retaining Ring, Probe Pin
*102	500458	1	Warning Label
103	401980	1	Bolt Knob
104	500488	1	Grip Handle
105	900223	1	Knob
106	900224	1	Label
107	500588	1	Label, Long/Short
108	900130	1	Handle
109	900117	1	Lever
110	900131	1	Retaining Ring
111	900124	1	Plunger
112	900126	1	Spring
113	091880	1	Roll Pin, Knob
114	501213	1	Logo, Magazine

* Denotes normal wear items

**NOTE: Make sure warning label (500458) is properly affixed. Replace if necessary. Label available at no charge through the Service Dept.

▲ Apply loctite 242 (Blue) Part No. 093500

→Denotes new change

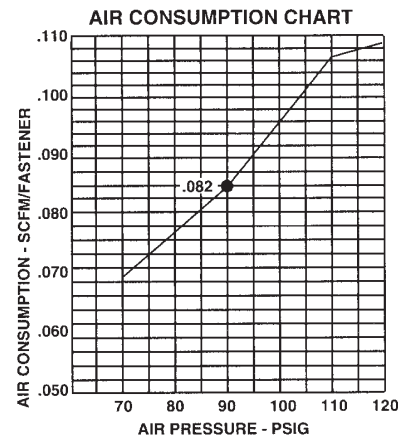

SPECIAL OPERATING INSTRUCTIONS

POSITIVE PLACEMENT OPERATION

This tool is equipped with a special probe dedicated solely for the use of locating the holes in metal hardware (such as straps, joist hangers, clips/framing anchors, etc.) Insert the probe into the hole. Firmly hold the tool and press the work contacting element against the work surface (metal hardware) until it is completely depressed. Squeeze trigger to drive the fastener. Lift the tool from the workpiece and repeat procedure for next fastener.

The tool is equipped with a specialized magazine, dedicated to driving four nail sizes:

- 1) 1-1/2" x .131
- 2) 1-1/2" x .148
- 3) 2-1/2" x .148
- 4) 2-1/2" x .162

The magazine has an adjustable mechanism which allows the operator to drive two different lengths of nails: long (2-1/2") and short (1-1/2").

To switch from one position to the other, pull out the "button" which unlocks the lever. Using the handle, rotate the lever to the other position and release the button. It will now be locked into the new position.

To drive 1-1/2" nails, place the lever in the upward "SHORT NAIL" position. To drive 2-1/2" nails, place the lever in the downward "LONG NAIL" position.

Should the lever not lock into place properly, remove the magazine assembly and clean out the lever area. Or, if necessary, remove the nose plate and lever mechanism by taking out the four socket head cap screws. Then, clean all dirt and debris and reassemble. (Refer to Tool Schematic.)

WARNING

Before switching positions, check the magazine to make sure it is free of all nails. Failure to do so can result in tool damage.

DANGER

USE ONLY GENUINE PASLODE HEAT TREATED NAILS TO AVOID SERIOUS INJURY FROM RICOCHETING FASTENERS.

COLOCACION PRECISA

Esta herramienta está equipada con un probador especial exclusiva para localizar orificios en piezas de metal (como perfiles laminados, cintas metálicas, anclajes de estructuras, sujetadores metálicos, etc.) Introduzca el probador en el orificio. Sostenga firmemente la herramienta y oprima el elemento de contacto contra la superficie de trabajo (pieza de metal) hasta que quede completamente oprimido. Oprime el gatillo para impulsar el sujetador. Separe la herramienta de la pieza de trabajo y repita el procedimiento para impulsar el siguiente sujetador. Esta herramienta está equipada con un cargador universal, capaz de clavar clavos de cuatro distintas longitudes:

- 1) 1-1/2" x .131
- 2) 1-1/2" x .148
- 3) 2-1/2" x .148
- 4) 2-1/2" x .162

El cargador tiene un mecanismo especial que permite clavar clavos de dos distintas longitudes largos (2-1/2 plg.) y cortos (1-1/2 plg.).

Para cambiar de una posición a la otra, tire hacia fuera del 'botón' que sujeta la palanca en posición. Con el mango, gire la palanca a la otra posición y suelte el botón. Así queda fija la palanca en la nueva posición.

Para impulsar clavos de 1 - 1/2 pulgadas coloque la palanca en la posición superior "SHORT NAIL". Para impulsar clavos de 2- 1/2 pulgadas coloque la palanca en la posición inferior "LONG NAIL".

Si la palanca no queda fija en su lugar, retire el conjunto del cargador y limpie el área de la palanca. Si es necesario puede desmontar la placa de la punta y el mecanismo de la palanca sacando los cuatro tornillos de cabeza hexagonal. Así puede limpiar el polvo y la suciedad de la palanca, y vuelva a armar. (Consulte el esquema de la herramienta.)

ADVERTENCIA

Antes de cambiar posiciones, revise que no haya clavos dentro del cargador. Si no lo hace, su herramienta se puede dañar.

PELIGRO

USE SOLAMENTE CLAVOS TERMOTRATADOS ORIGINALES DE PASLODE PARA EVITAR HERIDAS SERIAS DE SUJETADORES QUE REBOTEN.

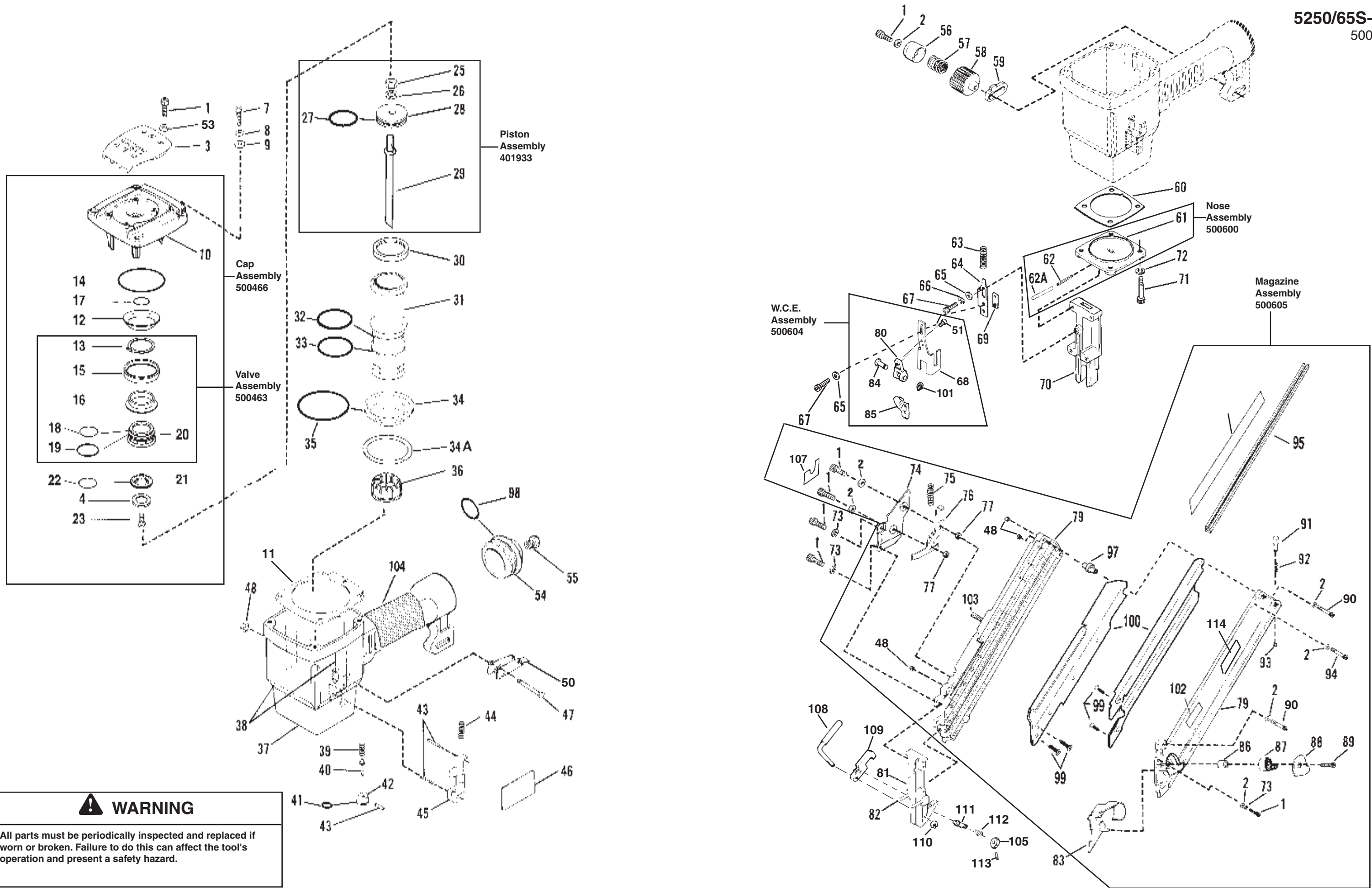

WARNING

All parts must be periodically inspected and replaced if worn or broken. Failure to do this can affect the tool's operation and present a safety hazard.

ACCESSORIES

Silencer Kit

This kit is used to minimize the sound of the air rushing out of the air deflector during tool operation.

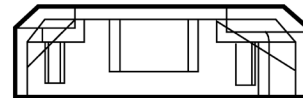

Part No. 402451

Remote Fire Valve

This valve via a positive air signal allows the machine mounted tool to be operated from an automatic air valve or foot pedal system.

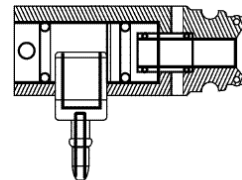

0713

Rafter Hanger Bracket

Allows tool to be hung over rafter during framing construction.

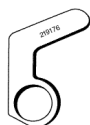

Part No. 219176

Hanger Bracket

Attaches to top of tool for storage or counter-balancing.

Part No. 1X0856

Lubricants

Lubricating Oil 16 oz.
Lubricating Oil with Antifreeze
Chemplex 710 Lubricant 1 lb.
Chemplex 710 Lubricant 5 gram tube



Part No. 403720
Part No. 219090
Part No. 403734
Part No. 219188

Degreaser Cleaner

Ideal Cleaner for all Paslode Tools



Part No. 219086

Safety Glasses

Clear



Part No. 402510

Framing Conversion Kit

This kit allows you to convert a 5250PP into a standard 5325 strip nailer.

Part No. 500601

Universal Belt Hook Kit

Attaches to cap enabling operator to carry tool on a belt holder (#219028).

Part No. 219017

Late Model 5000 Repair Kit

This kit repairs all leaks except for the trigger valve.

Part No. 219219

Trigger Valve Repair Kit

This kit repairs trigger valve air leaks.

Part No. 219224

SAFETY INSTRUCTIONS

WEAR EYE AND HEARING PROTECTION



Always wear hearing protection and eye protection devices, including side shields when operating or working in the vicinity of a tool.



Never use any bottled air or gases such as oxygen to operate the tool since they could cause the tool to explode.

DO NOT EXCEED MAXIMUM RECOMMENDED AIR PRESSURE

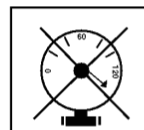

Operate the tool using only the recommended air pressure. Do not exceed the maximum air pressure marked on the tool. Be sure the air pressure gauge is operating properly and check it at least twice a day.

